

# Quick Selection Guide

## Signal Connectors

- M23 Coupling
- Bayonet Coupling

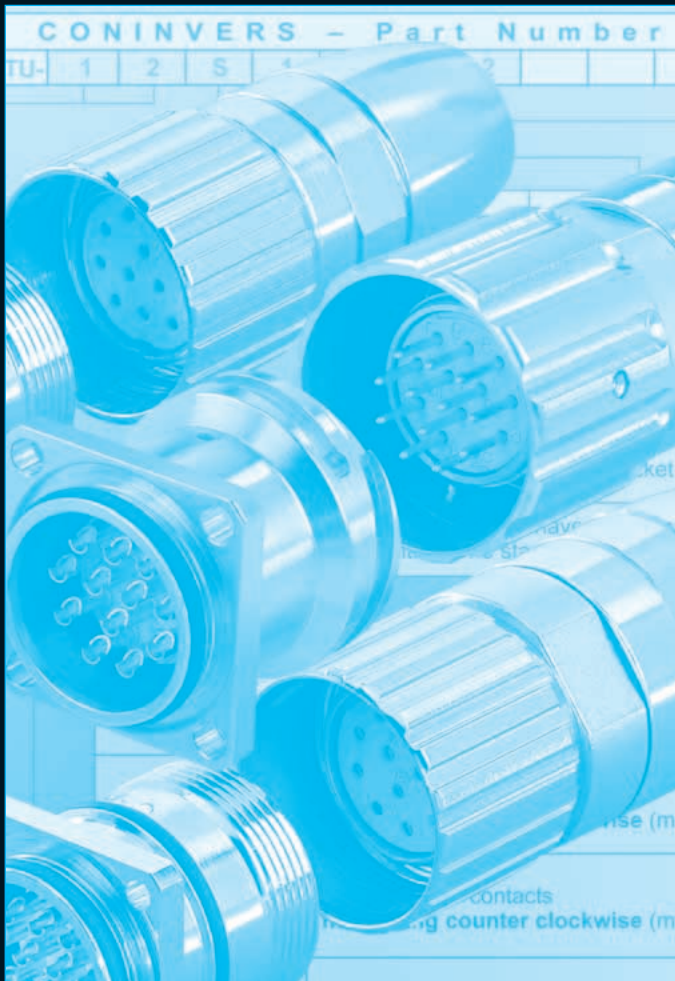

**CONINVERS®**

Edition 03/02

The first 7 digits out of the 11 digit part number define the contact insert.  
This applies for RC, UC and TU connector series.

CONINVERS - Part Number										
RC/UC/TU-	1	2	S	1	N	1	2			

**Number of Contacts**

(View: mating face)

	<b>06</b>	6 Positions
	<b>07</b>	7 Positions
	<b>09</b>	9 Positions (8+1)
	<b>63</b>	9 Positions (6+3)
	<b>12</b>	12 Positions
	<b>2R</b>	12 Pos. (11 + PE)
	<b>16</b>	16 Positions
	<b>17</b>	17 Positions
	<b>19</b>	19 Pos. (16 + 3)
	<b>1R</b>	19 Pos. (16 + 2 + PE)

**Style of Contacts**

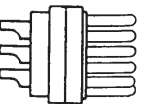
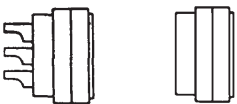
	
Contact inserts male (pin)	Contact inserts female (socket)
<b>P</b>	<b>S</b>

**Contact Insert Coding**

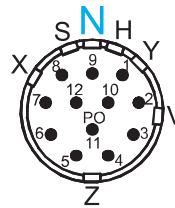

Pin

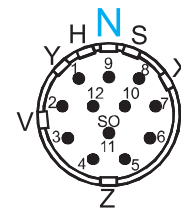

Socket





The standard coding is "N".  
Other coding options available on request.  
Not all codings are available for all No. of positions.

**Contact Terminations**

**Standard Versions**

- 12** = Solder Cup
  - 8A** = Crimp Style (up to 17 pos./ up to 0,75 mm<sup>2</sup>)
  - RA** = Crimp Style (16-19 pos./ up to 1,0 mm<sup>2</sup>)
  - S2** = Screw Style (6, 7, 9 pos.)
  - 22** = Dip Solder
  - 32** = Dip Solder (PCB mounting)
  - A2** = Crimp Style for receptacles in various lengths
  - C2** = Crimp Style for receptacles in various lengths
  - 42** = IP67 unmated (12 pos. only)
  - K2** = IP67 unmated (12 pos. only)
  - N2** = IP67 unmated (12 pos. only)
  - L2** = IP67 unmated (12 pos. only)
- Other on Request

**Contact Insert Numbering**

<b>1</b>		Insert with pin contacts <b>numbering clockwise</b> (mating face)
<b>1</b>		Insert with socket contacts <b>numbering counter clockwise</b> (mating face)
<b>2</b>		Insert with pin contacts <b>numbering counter clockwise</b> (mating face)
<b>2</b>		Insert with socket contacts <b>numbering clockwise</b> (mating face)



**CONINVERS - Part Number**

RC-							8	0	4	9
-----	--	--	--	--	--	--	---	---	---	---

Regarding the RC shielded connectors, the EMI accessories are defined by the last two digits as shown in the matrix below. This is not applicable to the UC / TU series.

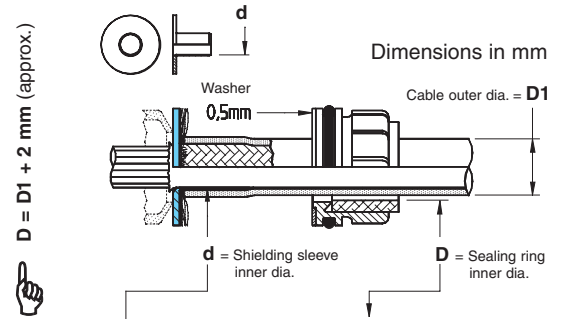

	4,0	5,0	6,0	7,5	8,5	10,0	11,0	NBR Univ.	FPM Univ.
2,5	53	57	E7					HA	MA
3,2		58	50	U7				HB	MB
3,6		A7	59	60	V7			HC	MC
3,8			61	62	Q5	99		HD	MD
4,1			54	56	P5	J8		HE	ME
4,3			W7	X9	Y9	Z9		HF	MF
4,6			X7	55	03	P8		HG	MG
4,9				J9	G6	P6		HH	MH
5,2				63	64	05		HJ	MJ
5,5				84	49	04	JC	HK	MK
5,8				H7	N8	07	E6	HL	ML
6,2					G5	NY	Q6	HM	MM
6,6					Q8	06	V5	HN	MN
7,0						52	L6	HP	MP
7,4						51	Q9	HQ	MQ
7,7						98	J0	HR	MR

Universal type: shielding disc / universal sealing ring for cable dia. up to 9,5 mm = EP

The last 4 digits out of the '11 digit part number' define the body style.

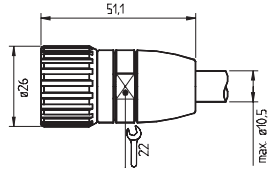

**80** Cable connector with integrated cable gland, max 10,5 mm cable dia., IP 67

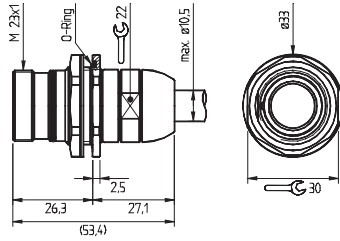

**00** Cable connector with integrated cable gland, max 10,5 mm cable dia., IP 67, for rear mounting to use as a receptacle

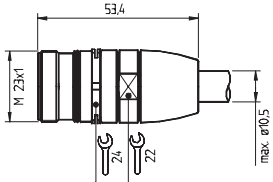

**90** Cable connecting receptacle with integrated cable gland, max 10,5 mm cable dia., IP 67, fits into connector with coupling nut

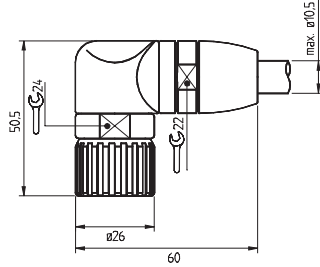

**10** Cable connector with integrated cable gland, max 10,5 mm cable dia., IP 67

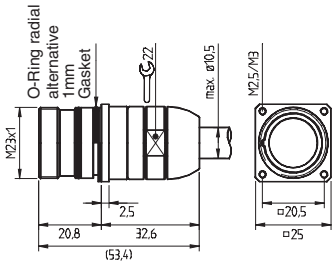

**00** Cable connector with integrated cable gland, max 10,5 mm cable dia., IP 67, for rear mounting to use as a receptacle  
**C0** With gasket, 4 threads M2,5  
**C1** With gasket, 4 threads M3  
**C2** With o-ring, 4 threads M2,5  
**C3** With o-ring, 4 threads M3

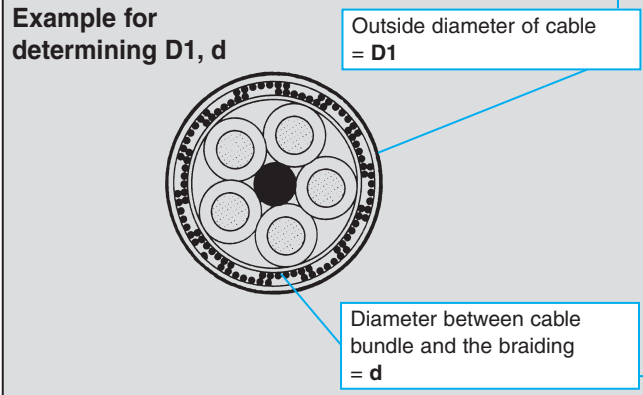

The last 4 digits out of the 11 digit part number define the body style.

CONINVERS - Part Number											
RC-								1	L	0	0

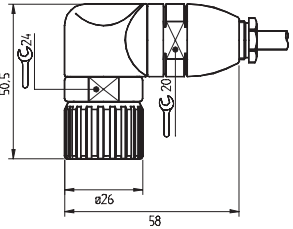

Cable connector with standard cable gland, PG 7 to PG 13,5  
**Z400** PG 7 cable entry 4-6 mm dia.  
**Z500** PG 9 cable entry 6-10 mm dia.  
**Z600** PG 11 cable entry 8-12 mm dia.  
**Z700** PG 13,5 cable entry 10-14 mm dia.

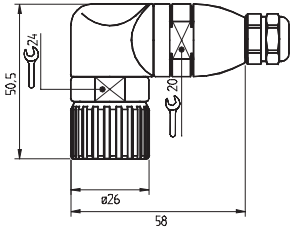

Cable connector with IP 68 cable gland, PG 7 to PG 13,5  
**ZH00** PG 7 cable entry 4-6 mm dia.  
**ZI00** PG 9 cable entry 6-10 mm dia.  
**ZK00** PG 11 cable entry 8-12 mm dia.  
**ZL00** PG 13,5 cable entry 10-14 mm dia.

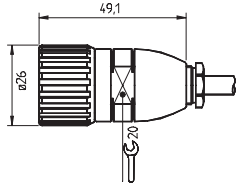

Cable connector with standard cable gland, PG 7 to PG 13,5  
**1400** PG 7 cable entry 4-6 mm dia.  
**1500** PG 9 cable entry 6-10 mm dia.  
**1600** PG 11 cable entry 8-12 mm dia.  
**1700** PG 13,5 cable entry 10-14 mm dia.

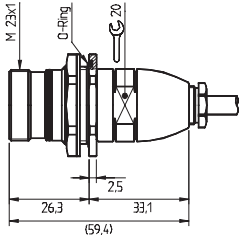

Receptacle, rear mounting, with standard cable gland, PG 7 to PG 13,5  
**G400** PG 7 cable entry 4-6 mm dia.  
**G500** PG 9 cable entry 6-10 mm dia.  
**G600** PG 11 cable entry 8-12 mm dia.  
**G700** PG 13,5 cable entry 10-14 mm dia.

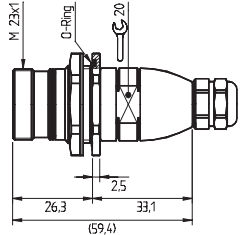

Receptacle, rear mounting, with IP 68 cable gland, PG 7 to PG 13,5  
**GH00** PG 7 cable entry 4-6 mm dia.  
**GI00** PG 9 cable entry 6-10 mm dia.  
**GK00** PG 11 cable entry 8-12 mm dia.  
**GL00** PG 13,5 cable entry 10-14 mm dia.

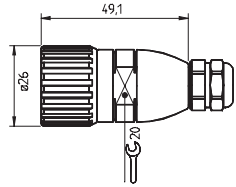

Cable connector with IP 68 cable gland, PG 7 to PG 13,5  
**1H00** PG 7 cable entry 4-6 mm dia.  
**1I00** PG 9 cable entry 6-10 mm dia.  
**1K00** PG 11 cable entry 8-12 mm dia.  
**1L00** PG 13,5 cable entry 10-14 mm dia.

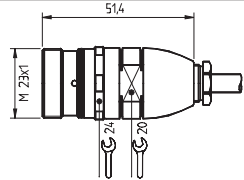

Cable connecting receptacle with standard cable gland, PG 7 to PG 13,5  
**7400** PG 7 cable entry 4-6 mm dia.  
**7500** PG 9 cable entry 6-10 mm dia.  
**7600** PG 11 cable entry 8-12 mm dia.  
**7700** PG 13,5 cable entry 10-14 mm dia.

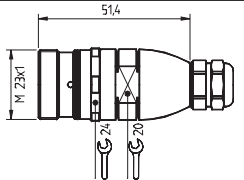

Cable connecting receptacle with IP 68 cable gland, PG 7 to PG 13,5  
**7H00** PG 7 cable entry 4-6 mm dia.  
**7I00** PG 9 cable entry 6-10 mm dia.  
**7K00** PG 11 cable entry 8-12 mm dia.  
**7L00** PG 13,5 cable entry 10-14 mm dia.

Further cable glands and metric threadings available on request

The last 4 digits out of the 11 digit part number define the body style.

CONINVERS - Part Number											
UC-								8	0	D	U

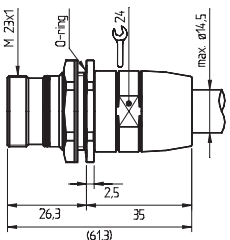

**Q0DU** Receptacle, rear mounting, with integrated cable gland, universal shielding, enlarged cable entry up to 14,5 mm dia., IP 67

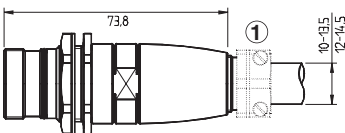

**Q3DU**  
**QNDU** Receptacle (long version), rear mounting, with additional strain relief, Pg 13,5 or Pg 16, universal shielding, enlarged cable entry up to 14,5 mm dia., IP 67  
PG 13,5 cable entry 10-13,5 mm dia.  
PG 16 cable entry 12-14,5 mm dia.

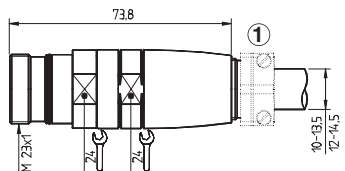

**F3DU**  
**FNDU** Cable connecting receptacle (long version), with additional strain relief, Pg 13,5 or Pg 16, universal shielding, enlarged cable entry up to 14,5 mm dia., IP 67  
PG 13,5 cable entry 10-13,5 mm dia.  
PG 16 cable entry 12-14,5 mm dia.

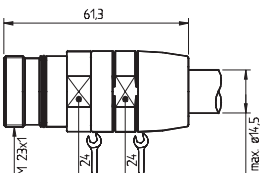

**90DU** Cable connecting receptacle with integrated cable gland, universal shielding, enlarged cable entry up to 14,5 mm dia., IP 67

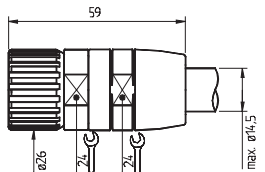

**80DU** Cable connector with integrated cable gland, universal shielding, enlarged cable entry up to 14,5 mm dia., IP 67

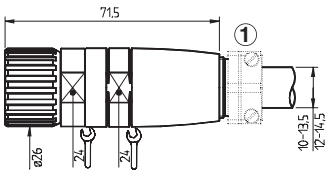

**R3DU**  
**RNDU** Cable connector (long version), with additional strain relief, Pg 13,5 or Pg 16, universal shielding, enlarged cable entry up to 14,5 mm dia., IP 67  
PG 13,5 cable entry 10-13,5 mm dia.  
PG 16 cable entry 12-14,5 mm dia.

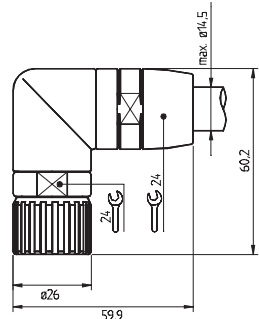

**TODU** Cable connector with integrated cable gland, universal shielding, enlarged cable entry up to 14,5 mm dia., IP 67

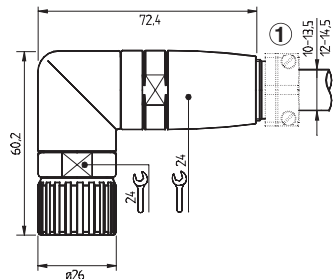

**N3DU**  
**NNDU** Cable connector (long version), with additional strain relief, Pg 13,5 or Pg 16, universal shielding, enlarged cable entry up to 14,5 mm dia., IP 67  
PG 13,5 cable entry 10-13,5 mm dia.  
PG 16 cable entry 12-14,5 mm dia.

Further cable glands and metric threadings available on request

Please order cable glands (IP 68 / double lever strain relief) separately

The last 4 digits out of the 11 digit part number define the body style.

**CONINVERS - Part Number**

TU-								8	U	D	U
-----	--	--	--	--	--	--	--	---	---	---	---

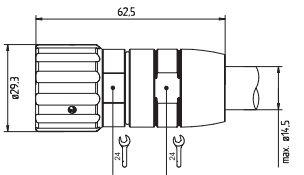

**8UDU** Cable connector with bayonet coupling, integrated cable gland, universal shielding, enlarged cable entry up to 14,5 mm dia., IP 67

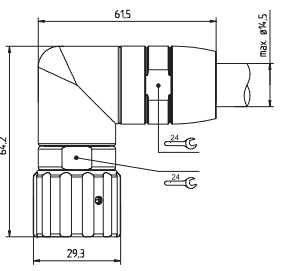

**TUDU** Cable connector with bayonet coupling, integrated cable gland, universal shielding, enlarged cable entry up to 14,5 mm dia., IP 67

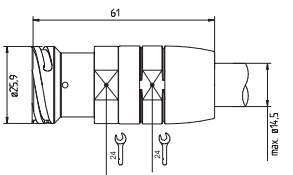

**9UDU** Cable connecting receptacle with bayonet coupling, integrated cable gland, universal shielding, enlarged cable entry up to 14,5 mm dia., IP 67

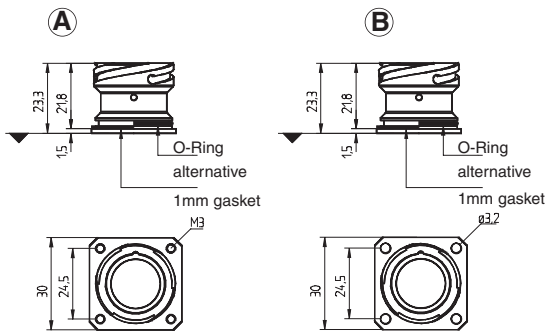

Receptacle with bayonet coupling, square flange, rear mounting

- 4100** With gasket, 4 threads M3 ] see fig. **A**
- 4300** With o-ring, 4 threads M3 ] see fig. **A**
- 5100** With gasket, 4 holes Ø 3,2 mm ] see fig. **B**
- 5300** With o-ring, 4 holes Ø 3,2 mm ] see fig. **B**

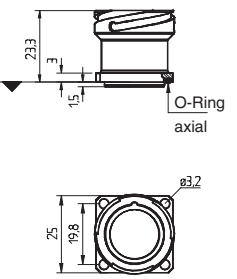

**WB00** Receptacle with bayonet coupling, square flange, front mounting  
With o-ring, 4 holes Ø 3,2 mm

**Mechanical Data**

<b>Shell material</b>	
Machined component by Copper-Zinc alloy (CuZn) , die cast component by Zinc (GD-Zn)	
<b>Shell plating</b>	
Nickel (standard), on request: black chromated, plastic molded	
<b>Insulator/flammability</b>	
Thermoplastic Polyester (PBT), Polyamid (PA 66), Polycarbonat (PC)/UL 94 V0	
<b>Contact material</b>	
Copper-Zinc alloy (CuZn)	
<b>Contact plating</b>	
Nickel (Ni) with Gold (Au) and passivated	
<b>Contact termination</b>	
Solder cup, dip solder, crimp type, screw type	
<b>Seal and O-Ring</b>	
Fluor rubber (FPM)	
<b>Gasket</b>	
Perbunan (NBR-stiffened gasket), Fluor rubber (FPM)	
<b>Temperature range</b>	
-40°C/+125°C (long term temperature)	
<b>Cable entry RC-Series</b>	
EMI version: outer dia. of cable 2 - 10,5 mm, without EMI protection: outer dia. of cable 4 - 14 mm	
<b>Cable entry UC/TU-Series</b>	
EMI version: outer dia. of cable 2 - 14,5 mm	
<b>Mating method</b>	<b>Mating cycles mechan.</b>
RC/UC-Series: threaded coupling M23; TU-Series: bayonet coupling	Standard: 50, higher on request
<b>Protection class</b>	
IP 67 mated, for EMI versions	
IP 65 - IP 68 mated, being subject to cable gland used, for versions without EMI protection	
<b>Approval RC-Series</b>	
UL-recognized File No 153698 (M) Underwriters Laboratories Inc.® 	

**Electrical Data**

Number of positions	6, 7	9(8+1)	9(6+3)	12 12(11+PE) 12 Hybrid	16 16(15+PE)	17 17(16+PE)	19(16+3) 19(16+2+PE)
Contact	6, 7	8 + 1	6 + 3	11, 12	15, 16	16, 17	16 + 3
Contact dia. (mm)	2	1 2	1 2	1	1	1	1 1,5
Rated current (A)	20	8 20	8 20	8	8	8	8 10
Rated voltage (V AC eff. / DC)	250	150	150	150	150	150	150
Test voltage (kV AC)	2,5	1,5	1,5	1,5	1,5	1,5	1,5
Overvoltage category <sup>1)</sup>	II	II	II	II	II	II	II
Insulation resistance (Ω)	≥10 <sup>16</sup>	≥10 <sup>16</sup>	≥10 <sup>12</sup>	≥10 <sup>12</sup>	≥10 <sup>12</sup>	≥10 <sup>12</sup>	≥10 <sup>12</sup>
Contact resistance (mΩ)	≤3	≤3	≤3	≤3	≤3	≤3	≤3
Pollution degree acc. to IEC 664-1	2 (3 <sup>1</sup> )	2 (3 <sup>1</sup> )	2 (3 <sup>1</sup> )	2 (3 <sup>1</sup> )	2 (3 <sup>1</sup> )	2 (3 <sup>1</sup> )	2 (3 <sup>1</sup> )

1) Reference: DIN EN 61984:2001

**Fax to: +49 (0) 70 32/92 74-330**

We desire a technical consultation regarding the products:

Description	Part No.
_____	_____
Description	Part No.
_____	_____
Description	Part No.
_____	_____
Description	Part No.
_____	_____

Please send us the CONINVERS Short Form Catalog

Contact Person	Dept.
_____	_____
Company	_____
Zip, City	Street
_____	_____
Phone/Fax	E-mail
_____	_____

