



For assembly tools, see pages 42-44

Please note: torque for screw termination

- max. 0.1 Nm for screw contacts with mating dia. 1 mm
- max. 0.2 Nm for screw contacts with mating dia. 2 mm

Cable Connectors and Cable Connecting Receptacles, Straight

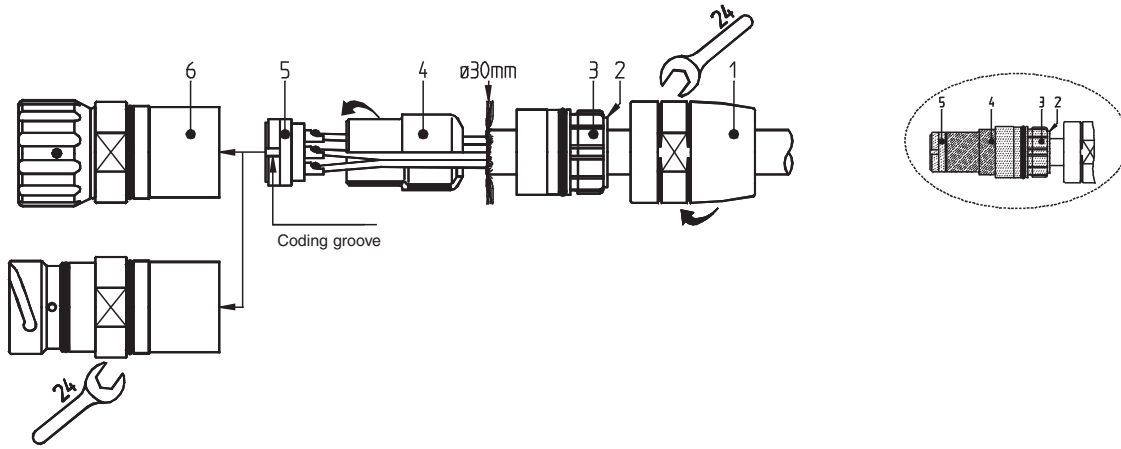

- Push the adapter (1) and the sealing element (3) with the gasket (2) onto the cable.
- Strip the external sheath by 30 mm.
- Push back the braided screen so it stands out at 90° and cut to length.
- Trim the foil, wadding and inner insulation.
- Strip the litz wires by 3.5 mm, twist (and tin plate).
- Solder, crimp or screw the litz wires to the contacts.
- Insert the spacer sleeve (4).
- Guide the insert (5), the spacer sleeve (4) and the sealing element (3) with the gasket (2) into the insert ring (6), taking care that the desired **coding groove** of the insert (5) is introduced **into the coding bar** of the spacer sleeve (6).
- Screw the adapter (1) **as tight as possible**.

Bayonet • TU Series Assembly Instructions



For assembly tools, see pages 42-44

Please note: torque for screw termination

- max. 0.1 Nm for screw contacts with mating dia. 1 mm
- max. 0.2 Nm for screw contacts with mating dia. 2 mm

Cable Connectors, Angled

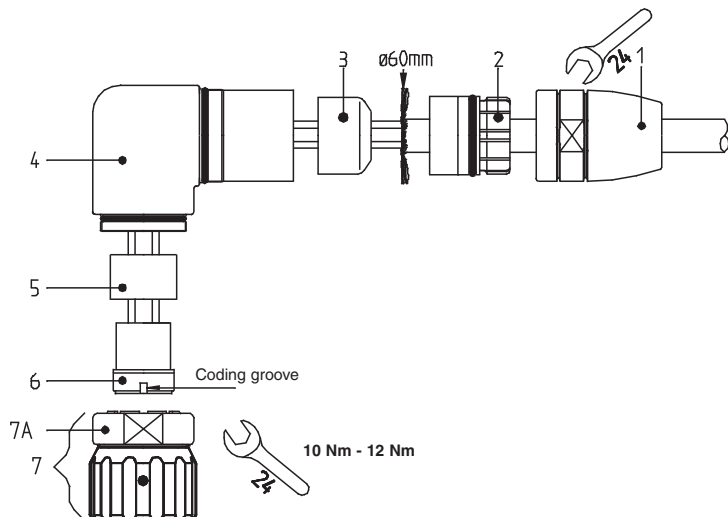

- Push the adapter (1) and sealing element (2) onto the cable.
- Strip the external sheath by 80 mm.
- Trim the foil, wadding and inner insulation.
- Push back the braided screen so it stands out at 90° and cut to length.
- Strip the litz wires by 6 mm.
- Solder, crimp or screw the litz wires to the contacts.
- Push the cable unit through the angle housing (4).
- Insert the spacer sleeve (3) into the angle housing (4).
- Push the sealing element (2) over the spacer sleeve (3) thus clamping the braided screen between sealing element and spacer sleeve.
- Push crimped contacts into the insert (6).
- Insert the spacer sleeve (5).
- Guide the insert (6) and spacer sleeve (5) into the unit (7), taking care that the desired **coding groove** of the insert (6) is introduced **into the coding bar**.
- Insert the entire unit into the angle housing. (Attention: eight coding options) and secure with nut (7A) (torque: 10 Nm up to 12 Nm).
- Screw the adapter (1) **as tight as possible**.